

Inhalt Teilkatalog DIN 2080

MAS-BT / Chiron / Stama / STS

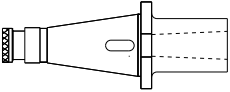
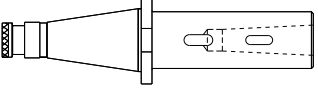
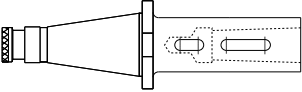
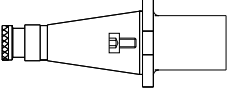
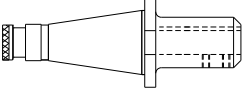
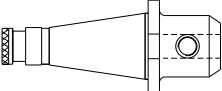
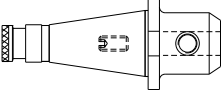
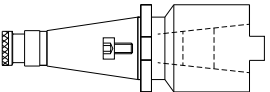
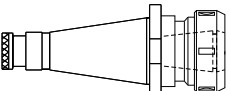
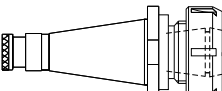
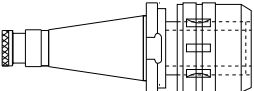
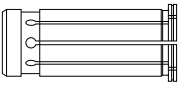
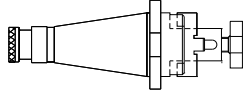
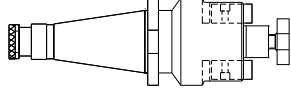
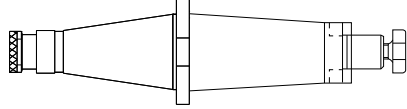
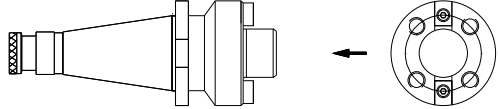
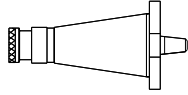
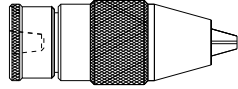
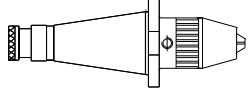
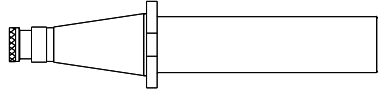
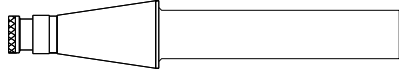
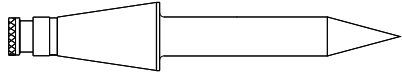
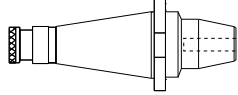
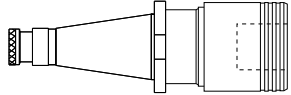

Einsatzhülsen kurz	Seite 1	
Werkzeugverlängerungen	Seite 2	
Einsatzhülsen lang	Seite 3	
Fräserhülsen	Seite 4	
Stellhülsenaufnahmen	Seite 5	
Weldonaufnahmen Form B DIN 1835	Seite 6	
Weldonaufnahmen System Whistle-Notch Form E DIN 1835	Seite 7	
Reduzierhülsen SK	Seite 8	
Spannzangenfutter System Rego-Fix DIN 6499	Seite 9	
Spannzangenfutter System Ortlieb DIN 6388	Seite 10	
Kraftspannfutter	Seite 11	
Spannzangen für Kraftspannfutter	Seite 11	

Kombi-Aufsteckfräserdorn	Seite 12	
Aufsteckfräserdorne	Seite 13	
Aufsteckfräserdorn lang	Seite 14	
Messerkopfaufnahmen	Seite 15	
Bohrfutteraufnahmen	Seite 16	
Präzisions-Bohrfutter	Seite 16	
NC-Kurzfohrfutter	Seite 17	
Rohlinge	Seite 18	
Prüfdorn	Seite 19	
Kontrollspitzen	Seite 20	
Hydro-Dehnspannfutter	Seite 21	
Gewindeschneid-Schnellwechselfutter	Seite 22	

Inhalt Teilkatalog DIN 2080

MAS-BT / Chiron / Stama / STS

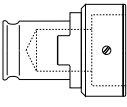
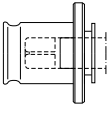
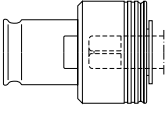
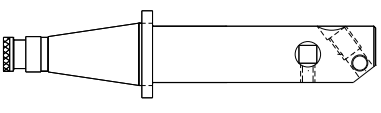

Schnellwechseleinsätze	Seite 23	
Schnellwechseleinsätze	Seite 24	
Schnellwechseleinsätze	Seite 25	
Kombi-Bohrstangen Form C	Seite 26	

Chiron/Stama

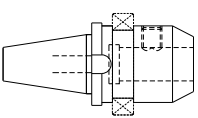
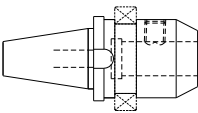
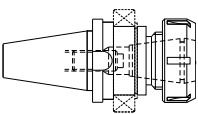
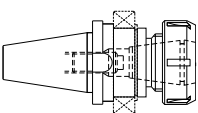
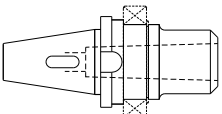
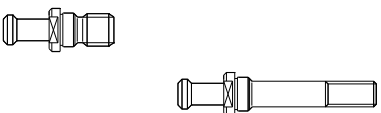
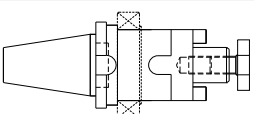
Weldonaufnahmen DIN 1835 Form B	Seite 27	
Weldonaufnahmen System Whistle-Notch DIN 1835 Form B	Seite 27	
Spannzangenfutter System Ortlieb DIN 6388	Seite 28	
Spannzangenfutter System Rego-Fix DIN 6499	Seite 28	
Kombi-Einsatzhülsen	Seite 29	
Anzugsbolzen	Seite 29	
Kombi-Aufsteckfräserdorne	Seite 30	

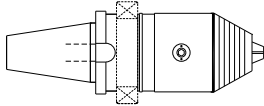
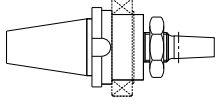
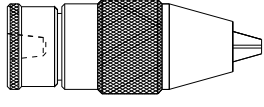
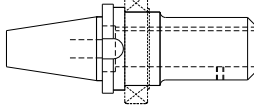
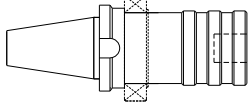
NC-Präzisions-Kurzbohrfutter	Seite 30	
Bohrfutteraufnahmen	Seite 31	
Präzisions-Bohrfutter	Seite 31	
Stellhülseaufnahme	Seite 32	
Gewindeschneidfutter	Seite 32	

MAS-BT

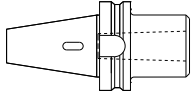
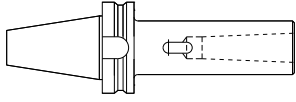
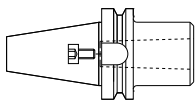
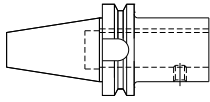
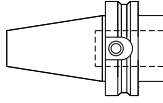
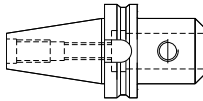
Einsatzhülsen	Seite 33	
Einsatzhülsen lang	Seite 34	
Fräserhülsen	Seite 35	
Stellhülseaufnahmen	Seite 36	
Weldonaufnahmen DIN 1835 B kurz	Seite 37	
Weldonaufnahmen Form B DIN 1835	Seite 38	

Inhalt Teilkatalog DIN 2080

MAS-BT / Chiron / Stama / STS

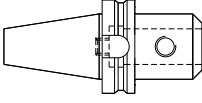
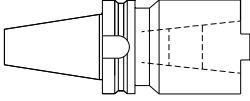
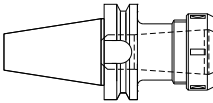
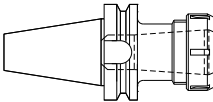
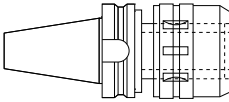
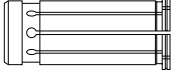
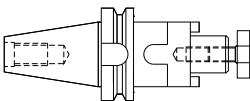
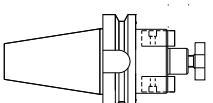
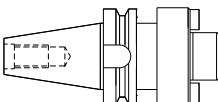
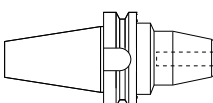
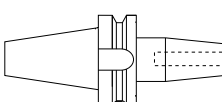
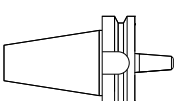

Weldonaufnahmen System Whistle-Notch Form E DIN 183	Seite 39	
Reduzierhülsen SK	Seite 40	
Spannzangenfutter System Ortlieb DIN 6388	Seite 41	
Spannzangenfutter System Rego-Fix DIN 6499	Seite 42	
Kraftspannfutter	Seite 43	
Spannzangen	Seite 43	
Kombi-Aufsteckfräserdorne	Seite 44	
Aufsteckfräserdorne mit vergrößerter Anlagefläche	Seite 45	
Messerkopfaufnahmen	Seite 46	
Hydro-Dehnspannfutter	Seite 47	
Schrumpffutter	Seite 48	
Bohrfutteraufnahmen	Seite 49	

Präzisions-Bohrfutter

Seite 49

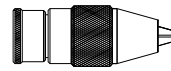

NC-Kurzbohrfutter

Seite 50

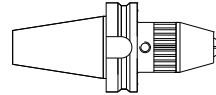

Rohlinge

Seite 51

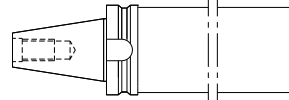

Gewindeschneid-
Schnellwechselfutter

Seite 52

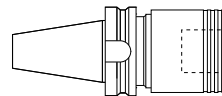

STS

Werkzeugaufnahmen STS
DIN 69871 AD/B

Seite 53

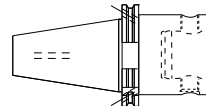

Werkzeugaufnahmen STS
DIN 2080

Seite 54

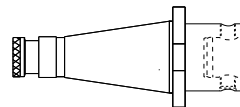

Werkzeugaufnahmen STS
MAS-BT

Seite 55

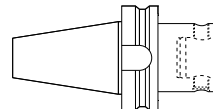

Werkzeugaufnahmen STS
HSK DIN 69893

Seite 56

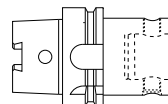

Werkzeugaufnahmen STS
DIN 69880

Seite 57

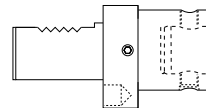

Verlängerungen STS

Seite 58

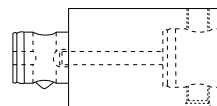

Reduzierungen STS

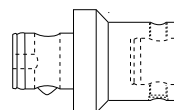

Seite 59



Inhalt Teilkatalog DIN 2080

MAS-BT / Chiron / Stama / STS

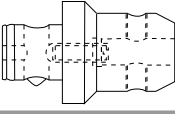
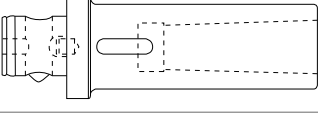
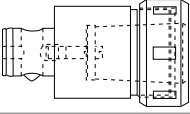
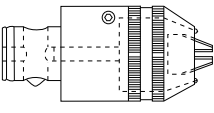
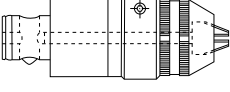

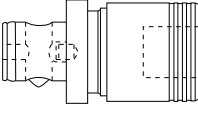
Weldenaufnahmen nach DIN 183 B STS	Seite 60	
Einsatzhülsen	Seite 61	
Spannzangenfutter System Ortlieb DIN 6388	Seite 61	
STS-NC-Bohrfutter	Seite 62	
STS-NC-Kurzbohrfutter	Seite 62	
Rohlinge	Seite 63	
Gewindeschneid- Schnellwechselfutter	Seite 64	

Alle Werkzeugaufnahmen

- aus legiertem Einsatzstahl, Zugfestigkeit über 800N / mm²,
Härte mind. HRC 58 +/-2
- Toleranzen gemäß DIN (eingengt)
- auf Wunsch, gegen Mehrpreis,
feingewuchtete Ausführung G 2,5 bei n=..... min⁻¹

